

SERIES 35-703

120 VAC Microprocessor-Based Intermittent Pilot Ignition Control

**F-35-703
March 2020**

FEATURES

- Safe start with DETECT-A-FLAME® flame sensing technology
- Custom pre-purge and inter-purge timings
- Single or three trials for ignition
- System diagnostic LED
- Local or remote flame sensing
- Automatic reset
- Open board, potted or enclosure

APPLICATIONS

- Commercial cooking
- Gas furnaces
- Unit heaters
- Water heaters
- Other gas-fired appliances

DESCRIPTION

The 35-703 is a 120 VAC intermittent pilot (IP) control designed for use in all types of gas-fired appliances. The control uses a microprocessor circuit to provide precise, repeatable timing and operating sequences. On-board diagnostics with LED output makes troubleshooting easy and ensures safe and efficient operation.

Export Information (USA)

Jurisdiction: EAR
ECCN: EAR99

Agency Certifications



Recognized under the UL component program, UL 372. Software certified to ANSI/UL 1998. UL File MH8817



Design Certified to ANSI Z21.20, CAN/CSA C22.2 No. 199-M89

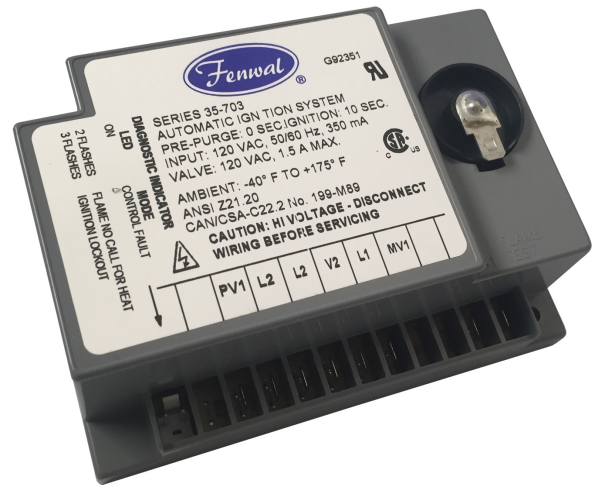

SPECIFICATIONS

Input Power	102 to 138 VAC, 50/60 Hz
Input Current	350 mA @120 VAC with main and pilot gas valve relays energized (control only)
Main Gas Valve	1.5A max @ 120 VAC
Pilot Gas Valve	1.5A max @ 120 VAC
Operating Temperature	-40°F to +160°F (-40°C to +71°C)
Storage Temperature	-40°F to +185°F (-40°C to +85°C)
Flame Sensitivity	1.0 µA minimum
Flame Failure Response	0.8 seconds maximum
Flame Detector Self-check Rate	Once per second minimum
Gas Types	Natural, LP, or manufactured
Spark Rate:	
Remote	50/60 sparks/sec
Local	25/30 sparks/sec
Size (LxWxH) with enclosure	5.11 x 3.55 x 2.00 inches (12.98 x 9.02 x 5.08 cm)
Moisture Resistance	Conformal coated to operate non-condensing to 95% R.H. Module should not be exposed to water
Ingress Protection	Not rated, protection provided by appliance in which it is installed
Tries for Ignition	One or three try versions available
Trial for Ignition Periods	15, 30, 60, 90 seconds available
Pre-purge and Inter-purge Timings	0, 15, 30, 45 seconds or 4 minutes available

SEQUENCE OF OPERATION / FLAME RECOVERY / SAFETY LOCKOUT

Start Up - Heat Mode

When a call for heat is received from the thermostat supplying 120VAC to L1, the control will reset, perform a self-check routine, flash the diagnostic LED and begin a pre-purge delay. Following the pre-purge period, the pilot gas valve is energized and sparking commences for the Trial For Ignition (TFI) period.

When flame is detected during the TFI, the sparking process is terminated and the main gas valve is energized. The thermostat and pilot burner flame are constantly monitored to assure proper system operation. When the thermostat is satisfied and the demand for heat ends, the pilot and main valves are immediately de-energized.

Failure to Light - Lockout

SINGLE TRIAL MODEL

Should the pilot burner fail to light, or the pilot flame is not detected during the TFI period, the pilot gas valve will de-energize and the control will go into lockout. The LED will indicate the fault code for ignition lockout.

MULTI TRIAL MODEL

Should the pilot burner fail to light or the pilot flame is not detected during the TFI period, the pilot gas valve will de-energize. The control will then go through an inter-purge delay before an additional ignition attempt. The control attempts two additional ignition trials before de-energizing the pilot gas valve and entering lockout. The LED will indicate the fault code for ignition lockout.

FLAME FAILURE - RE-IGNITION MODE

If the established pilot flame signal is lost while the burner is operating, the control will respond within 0.8 seconds by de-energizing the main gas valve and energizing the spark for the TFI period in an attempt to relight the flame. If the burner does not light within the TFI, the pilot gas valve will immediately de-energize and single try models will enter lockout. On multi-try models, a new TFI sequence will begin after an inter-purge delay. Multi-try models perform two additional attempts to light the burner before de-energizing the gas valves and entering lockout. If the pilot burner relights, normal operation resumes.

FLAME FAILURE-RECYCLE MODE

With the "Recycle After Loss of Flame" option, upon loss of flame, the pilot and main gas valves are de-energized and the control proceeds to inter-purge before attempting to relight the flame. Multi-try models permit three tries for ignition including inter-purges. If the pilot burner relights, normal operation resumes. If the pilot burner does not relight, the control will enter lockout.

Lockout Recovery

Recovery from lockout requires a manual reset by either resetting the thermostat, or removing 120 VAC for a period of 5 seconds. On models with automatic reset, if the thermostat is still calling for heat after one hour, then the control will automatically reset and attempt to ignite the burner.

MOUNTING AND WIRING

The Series 35-703 control is not position sensitive and can be mounted vertically or horizontally. The control may be mounted on any surface and fastened with #6 sheet metal screws. Secure the control in an area that will experience a minimum of vibration and remain below the maximum ambient temperature of 160°F (71°C).

All connections should be made with UL Approved, 105°C rated, 18 gauge, stranded, .054" thick insulated wire. Refer to the appropriate wiring diagram when connecting the 35-703 to other components in the system.

 CAUTION	All wiring must be performed in accordance with both local and national electrical codes.
---	---

 CAUTION	Label all wires prior to disconnection when servicing controls. Wiring errors may cause improper and dangerous operation. A functional checkout of a replacement control should always be performed.
---	--

 WARNING	This product uses voltages of shock hazard potential. Wiring and initial operation must be performed by a qualified service technician.
--	---

 WARNING	Operation outside specifications could result in failure of the Fenwal Controls product and other equipment with potential for injury to people and property.
---	---

Terminal Designations		
Terminal	Description	Quick Connect (inch)
PV1	Pilot Valve Power	3/16"
L2	120 VAC (Neutral)	3/16"
L2	120 VAC (Neutral)	3/16"
V2	Valve Neutral	3/16"
L1	120 VAC Input (Hot)	1/4"
MV1	Main Valve Power	1/4"
B. GND	Burner Ground	3/16"
S1	Remote Flame Sensor	1/4"

Wiring Diagrams - 35-703

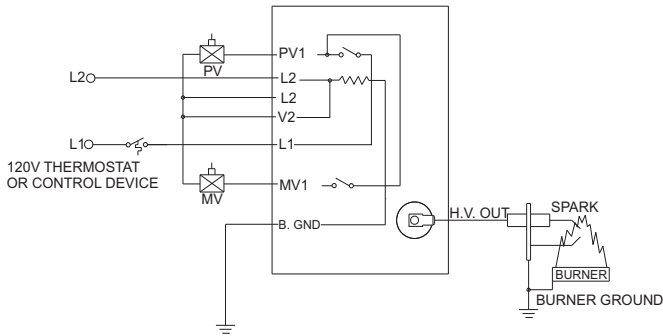

Figure 1. Local Sense

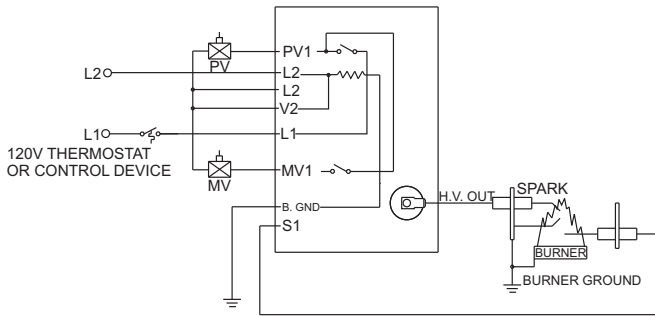

Figure 2. Remote Sense

Internal Control Failure

If the control detects a software or hardware error, all outputs are turned off and the LED displays a Steady On condition. If this condition persists after an attempt to restart, then the control must be replaced.

Proper Electrode Location

Proper location of electrode assembly is important for optimum system performance. The electrode assembly should be located so that the tips are inside the flame envelope and about 1/2-inch (1.2 cm) above the base of the flame as shown:

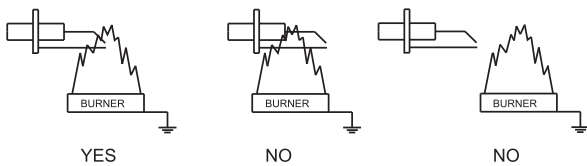

Notes:

- Ceramic insulators must not be in or close to the flame.
- Electrode assemblies must not be adjusted or disassembled. Electrodes are NOT field adjustable.
- Electrodes should have a gap spacing of 0.125 ± 0.031 in (3.12 ± 0.81 mm), unless otherwise specified by the appliance manufacturer. If spacing is not correct, the assembly must be replaced.
- Exceeding temperature limits can cause nuisance lockouts and premature electrode failure.
- Electrodes must be located where they are not exposed during normal operation.

TROUBLESHOOTING

Troubleshooting Guide	
Symptom	Recommended Actions
1. Control does not start	A. Miswired B. No 120VAC at L1 C. Fuse or circuit breaker fault D. Faulty control, check LED for fault codes
2. Thermostat on - no spark	A. Miswired B. Faulty thermostat, no voltage at terminal L1 C. Faulty control, check LED for fault codes
3. Valve on - no spark during TFI	A. Shorted electrode - establish 1/8-inch gap B. Check high voltage cable C. Miswired
4. Spark on - valve off	A. Valve coil open B. Valve wire disconnected C. Faulty control, check voltage at gas valve terminals PV1 or MV1 and V2
5. Flame okay during TFI - no flame sense after TFI	A. Check electrode position B. Check high voltage wire C. Poor ground at burner D. Poor flame, check flame current

Fault Conditions	
LED Indication	Fault Mode
Steady On	Internal Control Failure
2 Flashes	Pilot Flame without call for heat
3 Flashes	Ignition Lockout

Note: During a fault condition, the LED will flash on for 1/4 second and off for 1/4 second as needed to indicate the fault code. The code will repeat every 3 seconds. Removing power from the control will clear the fault code.

Flame Current Measurement

Flame current is the current that passes through the flame from sensor to ground. A good burner ground that matches the control ground is critical for reliable flame sensing.

LOCAL FLAME SENSE

With power off, connect a DC microamp meter as shown in the figure below. During the TFI, the meter should be protected from high voltage surge which could damage the meter. A jumper wire must be installed across the terminals of the meter. Once the flame is established, and sparking terminates, remove the jumper wire to measure flame current. The flame sense current must be 0.7 uA minimum for proper operation.

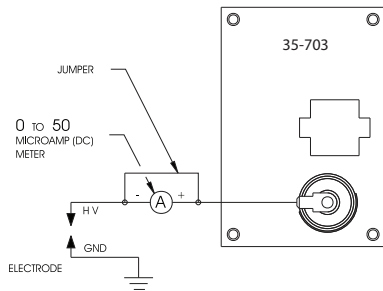

REMOTE FLAME SENSE

With power off, remove sense wire from S1 terminal, and install a DC microamp meter between the S1 terminal and sense wire. Establish flame, then measure flame current. The flame sense current must be 0.7 uA minimum for proper operation.

DIMENSIONS

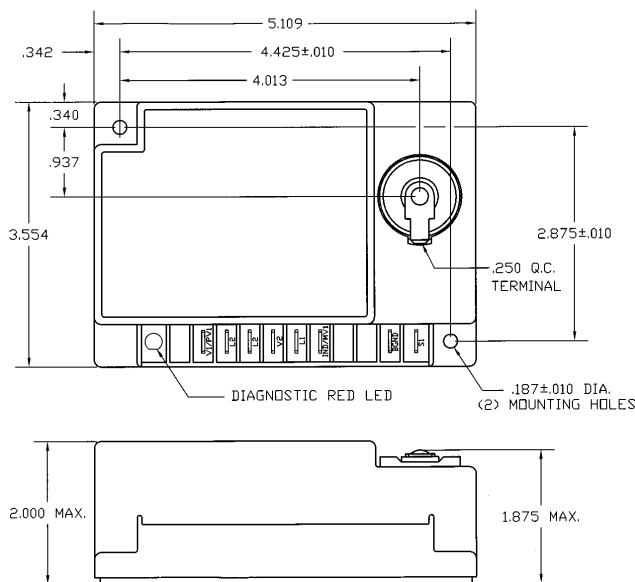

Figure 4. Enclosure

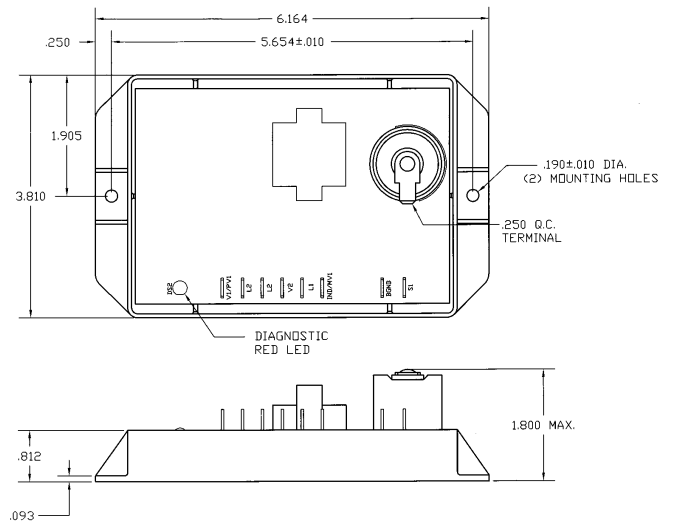

Figure 5. Potted

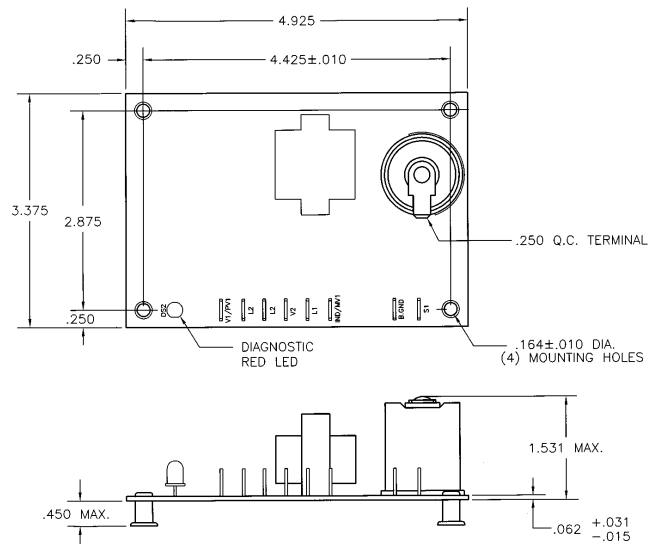

Figure 6. Integral Standoff

Note: All dimensions are in inches

PART NUMBER CONFIGURATION

SERIES 35-703 X 0 X - X X X

Configuration and Wiring Options

- 5 = Enclosure Quick Connect
- 6 = Integral Standoffs Quick Connect
- 7 = Potted Quick Connect
- 8 = Aftermarket Kit
- 9 = Special Configuration

An 8 or 9 in this location (i.e. 35-70 3[901]-113) indicates a special configuration. 9XX is a sequentially assigned part number and does not follow the standard part numbering configuration.

Consult Fenwal Controls for operating characteristics of this control.

Trial for Ignition

- 1 = 15 Seconds
- 3 = 30 Seconds
- 5 = 60 Seconds
- 7 = 90 Seconds

Inter-Purge

- 0 = None (Single Try Only)
- 1 = 15 Seconds
- 2 = 30 Seconds
- 3 = 45 seconds
- 4 = 4 minutes

Pre-Purge

- 0 = None
- 1 = 15 Seconds
- 2 = 30 Seconds
- 3 = 45 Seconds
- 4 = 4 minutes

Tries for Ignition, Flame Sense Method and Reset Method

- | | |
|-------------------------|------------------------------|
| 0 = 1 try, local sense | Thermostat / power off reset |
| 1 = 1 try, remote sense | Thermostat / power off reset |
| 2 = 1 try, local sense | Automatic reset |
| 3 = 1 try, remote sense | Automatic reset |
| 5 = 3 try, local sense | Thermostat / power off reset |
| 6 = 3 try, remote sense | Thermostat / power off reset |
| 7 = 3 try, local sense | Automatic reset |
| 8 = 3 try, remote sense | Automatic reset |

DETECT-A-FLAME is a registered trademark of Kidde-Fenwal, Inc., or its parents, subsidiaries, or affiliates.



Fenwal Controls, Kidde-Fenwal Inc.
400 Main Street
Ashland, MA 01721
Tel: 800-FENWAL-1
Fax: 508-881-7619
fenwalcontrols.com

This literature is provided for informational purposes only. KIDDE-FENWAL, INC. assumes no responsibility for the product's suitability for a particular application. The product must be properly applied to work correctly. If you need more information on this product, or if you have a particular problem or question, contact KIDDE-FENWAL, INC., Ashland, MA 01721.